



# **THE CHRYSLER COLLECTOR**

**Number 253  
March / April 2021**

**THE CHRYSLER RESTORERS CLUB OF AUSTRALIA, SOUTH AUSTRALIA INC.**

**Dodge & Plymouth**

**Parts 1924 to 1972  
SUSPENSION, BRAKE,  
ENGINE & BODY PARTS**

*If we haven't got the part you need, we'll try  
and get them for you.  
If you have parts for sale let us know.*

**BUY, SELL, SWAP OR TRADE**

**JIM ROBINSON  
DODGE AND PLYMOUTH PARTS,  
AUSTRALIA**

PO BOX 284 CLUNES VIC 3370  
PHONE/FAX: 03 5345 4094 H.H.L.  
MOBILE 0418 132 82  
Website: www.dodgeparts.com.au  
E-mail: jrobinson@giant.net.au

**Jim Robinson**  
**Dodge and Plymouth Parts Australia**  
ph 03 53 454094 / mob 0418 132821  
130 Beckworth Court Road  
Clunes Vic 3370

John Biddle's  
**Antique Motor Spares**

33 Fourth Street, Wingfield  
Ph 8268 5540  
Buy, sell, exchange.  
Large range of parts for all types of  
vintage and classic vehicle. Books.  
Tyres 4.50 x 21 and 5.00 x 19  
Hundreds of head gaskets in stock.  
Goode range of parts for Dodge, De  
Soto, Chrysler and Plymouth

**Delway Australia**

Restoration and repairs of brass and steel  
parts. Manufacture of brass and steel  
custom made items. Complete range of  
metal finishing services.

Sandblasting	Powder coating
Metal polishing	Metal spinning
Chrome plating	Gold plating

Supply of brass, steel and stainless steel  
extrusions. Repair, restore and rejuvenate.

30 Conmurra Avenue, Edwardstown SA 5039  
delway@internode.on.net www.delwaybrass.com.au  
Ph (08) 8277 0603 Fax (08) 8374 1359

**Goode Restorations**

34 New Road, Clare 5453  
Ph 8842 3731  
Specialising in rewooding vintage  
car bodies.  
Restorers of vintage and classic  
motor vehicles.

**Pat McGrath Plumbing**

**For All Your Domestic and Commercial  
Plumbing Needs**

Sewer and stormwater drainage specialist  
New homes and additions  
Bathroom renovations  
Hot and cold water systems  
Gas fitting  
Mini excavator and backhoe hire  
General maintenance  
Servicing All Areas

**Phone: 0409 404 940**



## CLUB DIRECTORY

# The Chrysler Restorers Club of Australia, South Australia Inc.

*Established in 1980, catering for the following vehicles:*

Dodge \* Plymouth \* De Soto \* Chrysler \* Imperial \* Maxwell \* Fargo \* Graham Brothers \* Valiant

### Postal Address

PO Box 667, Plympton SA 5038

### Meetings

Meetings are held at the Combined Car Clubs (Triple C) Club rooms, Glandore Community Centre, Clark Avenue, Glandore at 7:45 pm on the second Wednesday of each month, except January. Entry to club rooms is through the car park. Visitors and guests are welcome. Please bring supper to share.

### Subscriptions

Metro single \$35.00 - Metro family \$40.00 - Country single \$25.00 - Country family \$30.00

### Club Officers

<b>President:</b>	Greg Lind, 56 Currawong Crescent, Modbury Heights 5092..... ah 0417 853 291
<b>Vice President:</b>	Brenton Gibb, 18 Caroonia Avenue, Modbury Heights 5092 ..... ah 08 8263 2908
<b>Secretary:</b>	Ann Lind, 56 Currawong Crescent, Modbury Heights 5092..... ah 0417 853 291
<b>Asst. Secretary:</b>	John Goddard, 22 Stephens Terrace, Torrensville 5031..... ah 08 8443 6311
<b>Treasurer:</b>	Alan Driver, 6 Hastings Road, Brighton 5048 ..... 08 8298 1194
<b>Editor:</b>	Richard Tapp, 17 Simpson Parade, Goodwood 5034 ..... ah 0439 682 011
<b>Assist. Editor:</b>	Bob Haywood, 2 Rosemary Street, Woodville West 5011..... 0407 601 803
<b>Librarian:</b>	Stephen Tyler, PO Box 5266, Murray Bridge 5253 ..... ah 0432 557 937
<b>Assist. Librarian:</b>	Andrew Kloot, 12 Kelleway Street, Parafield Gardens 5107 ..... 0439 858 944
<b>Technical Liaison:</b>	Chris Howes, 4 Peter Place, Campbelltown 5074 ..... 08 8165 3971
<b>Public Relations:</b>	John Goddard, 22 Stephens Avenue, Torrensville 5031..... ah 0435 107 854
<b>Runs Coordinator:</b>	Brenton Gibb, 18 Caroonia Avenue, Modbury Heights 5092 ..... ah 08 8263 2908
<b>M/ship Vehicle Records:</b>	Sharon Gibb 18 Caroonia Avenue, Modbury Heights 5092..... ah 08 8263 2908
<b>Historic V Registrar:</b>	Chris Bennett, Clarence Park..... 0418 802 764
<b>Committee:</b>	Bob Haywood, 2 Rosemary Street, Woodville West 5011..... 0407 601 803
	Carolyn Harris, 17 Waterview Crescent, O'Halloran Hill 5158 ..... ah 08 8322 1715
	Jeff Knowles, 7 Stanley Street, Hillbank 5112 ..... 08 8255 8671
	Ian Myers, 12 Liddell Drive, Huntfield Heights, 5163..... 0411 576 775
<b>Federation Rep:</b>	Alan Driver, 6 Hastings Road, Brighton 5048..... ah 8298 1194
<b>Combined Car Clubs Rep:</b>	Vince Isola, 4 Grigg Court, Clarence Gardens 5039 ..... 08 7007 4461
<b>Public Officer:</b>	Barry Maslin, 13 Walthamstowe Road, Old Noarlunga 5168 ..... 08 8386 2931
<b>Auditor:</b>	Michael Bartsch, 105 Billabong Road, Modbury Heights 5092..... ah 08 8395 3919
<b>Catering Coordinator:</b>	Carolyn Harris, 17 Waterview Crescent, O'Halloran Hill 5158 ..... ah 08 8322 1715

**Club Tools held at:** Chris Howes, 4 Peter Place, Campbelltown 5074 ..... ah 08 8165 3971

*Note that most committee members have e-mail access. You will find their e-mail addresses on the contacts page of the website, where they can be protected from harvesting by spam robots. Addresses listed in the web version of the magazine can not be protected.*

Website: [chrysler-restorers-sa.org.au](http://chrysler-restorers-sa.org.au)

Facebook: [facebook.com/groups/chryslerclubsa](https://facebook.com/groups/chryslerclubsa)

Photos: [flickr.com/photos/164632874@N04/albums](https://flickr.com/photos/164632874@N04/albums)

## The Chrysler Collector

**Next Issue:** Please submit material for the next issue **no later than Friday 30 April 2021. Only corrections/ amendments accepted Sunday 2 May 2020.** Contributions can be e-mailed to [editor@chrysler-restorers-sa.org.au](mailto:editor@chrysler-restorers-sa.org.au) or posted to 17 Simpson Parade, Goodwood SA 5034 or brought to club meetings. E-mailed digital photos should preferably be at least 1200x900, photos should be scanned at 200 dpi; line-art at 600 dpi. **Copyright:** All material published in The Chrysler Collector is the copyright of the author of the article or the photographer. Their permission should be sought before reproduction. The magazine is available in colour on our [website](http://website).

## COMING EVENTS

### CLUB MEETINGS

**Wednesday 10 March 2021**

*Covid rules permitting*

### CLUB RUNS / EVENTS

**Saturday 13th March 2021**

Twilight Cruise

**Sunday 21st March 2021**

Adelaide Chrysler Festival Display Day held on the Gaza Sports and Community Club Oval North East Rd Klemzig (by the OG Hotel)

**Sunday 18th April 2021**

Cruise to Angle Vale, Morning Tea Stop and Inspection of Laserworx business and then onto Lyndoch for Lunch.

**Saturday 15th May 2021**

Cruise to Mt Pleasant Farmers Market and back to Birdwood and visit The National Motor Museum.

**Saturday 5th June 2021**

Club Registration Day at the CCC Clubrooms.

**Sunday 18th July 2021**

Run to Mannum and lunch at the Mannum Club.

### INVITATION/OTHER CLUB'S EVENTS

**Friday 19th Saturday 20th**

**Sunday 21st March 2021**

Adelaide Chrysler Festival.

**Sunday 21st March 2021**

The Northern Automotive Restoration Club Show 'n' shine Clare Oval

**Sunday 21st March 2021**

Historic Motor Vehicle Gathering 10.30 am until 3.00 pm. Old Edwards Park Netball Courts Adelaide Parklands Anzac Highway for pre 1930 self-propelled vehicles.

**Sunday 11th April 2021**

Veteran & Vintage Run from Gawler to the Barossa. For Vehicles up to and including 1930. Entry forms available Brenton Gibb

**Saturday and Sunday 17th & 18th April 2021**

All Historic Race Meet at Mallala Race Way (First Outing of the Clem Smith Charger since its Restoration)

**Saturday 24th April 2021**

Classics on the Park at Virgara Winery. Hosted by the Gawler Veteran, Vintage and Classic Vehicle Club Heaslip Rd Angle Vale. For more info: [classicsonthepark@gawlerclub.com](mailto:classicsonthepark@gawlerclub.com)

**Sunday 23 May 2021**

Copper Coast Classic Cavalcade of Cars and Motorcycles. Entries close on the 14th May 2021. Entry forms are to be done on line.

### SWAP MEETS

*Not currently swapping ...*

### Entry Forms etc.

*Club events co-ordinator Brenton Gibb has contact details and / or entry forms for other club's events.*

## 2022 National Rally

The Chrysler Restorers Club of Australia, Victoria Inc has begun planning for the 2022 National Chrysler Rally to be held in Wangaratta in 2022 (Sept 25th to 1st October).

Despite the disruption caused by the Covid-19 lockdowns a sub-committee has been formed to begin the planning of the rally, and although it is early days still, we are hoping that we can keep on track to deliver a spectacular rally centred in the old bushranger territories around Wangaratta in North Central Victoria.

We will provide updates when appropriate, but the next significant milestone is the release of

entry forms in late 2021.

Stay safe - we would love to see you all at what is sure to be another memorable event organised by the state that does things better! (lockdowns, curfews, hotel quarantine, covid-19 controls, and AFL Grand Finals excepted)

**Mark Fenton**  
*Secretary*

**Chrysler Restorers Club of Australia (Vic) Inc**

## Membership / Records

### NEW MEMBERS

None

## Cover Photo

**Doug and Yvonne Sweetman's 1938 De Soto SP5 - Photo Richard Tapp 2021 Valentine's Day run**

## COMING EVENTS

### Twilight Cruise

**Saturday 13th March 2021**

Meet at the CCC Clubrooms 5.45pm for a 6.00pm departure for a short metropolitan coastal

cruise followed by a picnic on the banks of the Pat. Bring your own chairs, drinks and tea or stop off and get something at a local shop.

**Brenton Gibb**  
8263 2908

### All Chrysler Festival Display Day

**Sunday 21<sup>st</sup> March 2021**

Our Club would like to attend this event and display as many of our club vehicles as possible, so if you are keen to attend, please inform me so I can reserve an area for us.

At the time of writing this all information has not been

released, but I feel we will need to register with The Chrysler Car Club of SA to meet their Covid Tracing requirements.

This is a great opportunity for us to show case the variety of vehicles within our club and hopefully gain some new members. I believe the theme

this year is the 50<sup>th</sup> anniversary on the birth of the mighty Charger, so dust off those Chargers and bring them along.

This year's event is to be held on the Gaza Sports and Community Club Oval on North East Rd Klemzig (Next to the OG Hotel)

### Laserworx Manufacturing Tour

**Sunday 18<sup>th</sup> April 2021**

Meet at the Gepps Cross Home Maker Centre 9.15am for a 9.30am departure to Angle Vale arriving around 10.00am.

We will be split into groups of 13 people for each viewing session. Morning Tea provided by the local Lions Club and then on to Lyndoch for a packed lunch or purchase something from the local bakery.

**John Goddard**  
0435 107 854

See page 7 for more information about Laserworx



### Mt Pleasant Farmer's Market & National Motor Museum

**Saturday 15<sup>th</sup> May 2021**

Meet at Waterworld Aquatic Centre carpark – City of Tea Tree Gully, (on the corner of Jack High Lane and Golden Grove Road Ridgehaven), 8am for an 8.30am departure.

Around a 45 minute run to Mt Pleasant Farmers Market (reserved parking area gold coin

donation) for a catered breakfast, cost from \$5.00 for egg roll to around \$15.00 for bacon, sausage, egg, tomato and mushrooms before having the opportunity to purchase fresh county produce from the stall holders and then back to the National Motor Museum Birdwood. Free entry to the Mill, with off street parking within the

grounds.

A great opportunity to view the new Holden display, with many experimental vehicles not seen by the general public before. Cafés and Bakery in Birdwood for lunch if you are still hungry.

**Chris Howes**  
08 8165 3971

### Club Registration Day

**Saturday 5<sup>th</sup> June 2021**

Held at the CCC Clubrooms.

Please come along and renew your club membership and if you have vehicles on club registration please bring all of the relevant paper work with you.

All of the paper work will be forwarded to you with the next magazine. There may be some minor changes as to the number of people allowed in the club rooms at any one time due to Covid 19 restrictions.

Time is between 10am and 2pm.

## FROM THE COMMITTEE

### President's Message



Welcome to the March/April 2021 Chrysler Collector Magazine. I hope all our members are well.

On the 17<sup>th</sup> of January our President's Breakfast run was organised by Vince Isola at a lovely park in the Henley Beach area. The morning was a little brisk, however the sun came out and warmed us all up which was great. We had a pretty good attendance around 15-20 cars. It was a good chance to catch up with members after Christmas and have a nice relaxing breakfast and a good chat. Thanks again to Vince for organizing this event, as you know I can't keep a secret.

Wednesday the 10<sup>th</sup> February saw our first club meeting for the year being held in a slightly different location – on the lawns outside the CCC clubrooms. Starting the meeting at 7.30pm sharp with about 45 members in attendance the meeting finished at around 8.30pm with the mosquitoes just starting to bite. However, this did not stop Vince Isola from setting up his supper along with Alan Pike and the usual gang.

The following Sunday we were back at the CCC clubrooms for the breakfast run to

the Hahndorf Inn. A great day with 54 members attending. Thanks to Brenton and Sharon Gibb for organising this event.

The 10<sup>th</sup> of March meeting will be held in the same format unless we have any new updates regarding use of the CCC clubrooms.

At our last committee meeting Brenton Gibb discussed the next few months club runs, please support our club by attending as many events as possible, so keep an eye out for coming club events.

On Sunday 21<sup>st</sup> March Brenton will be organizing a club run to the Adelaide Chrysler Festival at Gaza Oval on North East Road, Klemzig. We will be holding a club display on the day and it will be a good chance to show off your cars and also a chance for club members to get together during these strange times.

I look forward to meeting up with you all at the coming events. Keep up your continuing support for our club and hopefully things will be back to some kind of normal in the near future.

Stay safe and keep motoring.

*Greg Lind  
President*

## From the Editor

### CONTRIBUTORS

This issue comes to you courtesy of Brenton and Sharon Gibb, Mark Fenton, Greg and Ann Lind, John Goddard, Chris Howes, Trevor Beythien and Terry Jones.

Many thanks to the magazine despatch team, being Sharon and Brenton Gibb and Ann and Greg Lind,

*Please submit articles and entries to the magazine as early as possible but no later than the Friday date shown on page 3.*

### WEBSITE STATISTICS

	Jan 21	Feb 21	Feb 20	Feb 11
Sessions	236	179	195	1101
Users	168	133	159	309
Page views	513	383	401	9636
Pages/session	2.2	2.1	2.1	8.8
Average session (m:ss)	2:18	1:44	1:25	2:42
Flickr views		665k		-
Facebook mbrs	807	847	409	-

## CLUB NOTES

### Comin Events - Laserworx

*More information about the club run on 18 April 2021.*

I was introduced to Laserworx when I attended a run in my sister, Diane and brother in law Gary's Buick. They are members of the Cadillac and La Salle car club.

Laserworx is owned and run by Frank O'Riley who is a member of the same club.

Frank's backyard shed houses the equipment which includes his Laser machine and a CNC router which he built himself.

I found the visit very informative and interesting. His wares are plaques with car emblems and wooden dolls house's which are laser cut, which fit together to make walls etc. He also etches glasses and bottles.

Frank runs his machines so you get to see them at work.

Hope to see you there.

*John Goddard*

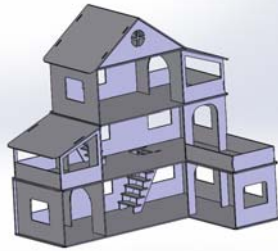

## PAST EVENTS

### Minutes of the Meeting held 10th February 2021

#### **The Chrysler Restorers Club of Australia, SA Inc.**

##### **Summary of minutes of the meeting held 10 February 2021 – commenced at 7:30pm.**

Meeting was held on the lawns outside the CCC clubrooms in keeping with regulations of no more than 40 in the CCC clubrooms. Covid19 QR code and contact tracing forms were completed. Covid19 marshals on site.

#### **Emergency Wardens**

G Lind explained emergency response plan.

#### **Apologies:**

Per attendance book

#### **New Members & Visitors**

None

#### **Trevor Kramm**

Trevor passed away on 7 February 2021.

#### **Sick List**

Les Johnson

#### **Birthdays**

Alan Pike celebrated his 80th birthday

#### **Minutes Previous Meeting**

Read and moved by A Lind, seconded J Knowles, carried.

#### **Correspondence**

**In/Out** CCC 28/11/20 regarding COVID-19-Safe check in and QR code update; CCC 1/12/20 – COVID-19 Safe Plan – 20 people allowed in clubrooms; CCC 14/12/20 – COVID-19 Safe Plan – 40 people allowed in clubrooms – this is still current; membership enquiry – passed onto Sharon Gibb; CCC committee meeting 7th December; re car parts forwarded to Richard Tapp for inclusion in magazine; from Barry Maslin re renewal of Dodge Bros membership copied from email sent to Alan Driver regarding payment; Paul and Therese Whitton advising of his transfer to Canberra. Email was forwarded to Sharon Gibb for alteration of records; 27/1/21 To Whitton's wishing them well; 8/2/21 – to Cynthia Davey CCC regarding what time the sprinklers come regarding our outside meeting on 10th Feb; 8/2/21 – CCC Cynthia Davey regarding sprinklers – should be ok; 9/2/21 – CCC – Re Glandore community reserve – new play area being installed; 9/2/21 – CCC Minutes of committee meeting held 1/2/21; various forwarded to Brenton Gibb regarding upcoming events and information for club runs; Thank you email from Ford Owners Club for recognition of their donation. City of Holdfast Bay Community event – Meet the machines 10/10/19. Club Magazines – Auto Torque, Chrysler News Qld, Morris Car Club.

**Out** Letter of thanks to SAPOL for their guest speaker Rob Grinter. Letter of thanks to Ford Owners Car Club for their donation of VH/CH Valiant manual.

Club Database update to FHMC after our AGM. City of Holdfast Bay Community Event – apology.

#### **Treasurer's Report**

A Driver moved report to be correct, seconded B Gibb, carried. Various accounts passed for payment.

#### **Committee Reports**

*Runs Coordinator* – Brenton Gibb spoke re future events

*Editor* – Richard Tapp - Keep sending in articles.

*Public Relations* – John Goddard - not much happening at the moment

*Records* – Sharon Gibb - All good

*Librarian* – Library not operating at the moment

*Tech Rep* – Busy with emails and phone calls

*HVR* – Chris Bennett - all good.

*Triple C* – Vince Isola - Simca Car Club is joining

*Federation Rep* – A Driver - meeting 13/2/21.

Federation has waived fees for 20/21

#### **Past Events**

Greg Lind spoke about the January run organised by Vince Isola.

#### **General Business**

Chris Howes spoke to the members regarding the donation by Mitsubishi of a large quantity of material to the Birdwood Motor Museum. He advised the meeting that a few members of the club were involved in obtaining quite a bit of Chrysler, Roots Group and other information from the Chrysler site before it was closed down. We have a number of filing cabinets which could be donated to the Birdwood Motor Museum. This would be a good way to preserve this information in an environment where it would all be catalogued and placed in the museum's library. 30 years ago a document was signed between Mitsubishi and the Chrysler Restorer's Club of Aust, SA Inc and the ramifications of this have to be explored. This issue will be discussed further at the committee meeting being held on the 21/2/21.

Jeff Knowles advised meeting that he has started a list of people who are interested in a badge for the 40th Anniversary Celebration Day at Balaklava. Anyone who wants to put their name on the list see Jeff.

Bob Haywood advised meeting he has a few calendars left – price \$10.00

#### **Raffle**

Not held.

#### **Conclusion**

Kevin Williams told a joke in memory of Ron Hincks President summarised the coming events.

Meeting closed at 8.45 pm

# MOPAR MECHANIC

## Power Steering for 1956

# POWER-STEERING IN AUST.

### Surprise "extra" for Plymouth, Dodge, and De Soto

**S**URPRISE introduction of power-steering on Plymouth, Dodge, and De Soto cars was announced by Chrysler Australia Ltd. last month.

The equipment is available as an optional "extra" for £75 plus tax.

Popular in the big-car field overseas, power-steering has not been seen in this country other than on a very small number of specially-imported American cars.

Power-assisted steering has many advantages:

- It relieves the driver of 80 percent of the effort required to turn the wheels.
- It takes the fatigue out of driving but retains driving "feel of the road."
- It makes parking much easier because the wheels can be turned from lock to lock with one finger.
- It makes driving safer because the steering responds quicker and the wheels are not so easily thrown off course by a bump.
- The driver has much better control in cases of emergency, such as a blowout.

Application of a light pull (about one to two pounds) on the rim of the steering wheel brings the power system into action.

The hydraulic unit is perfectly safe.

In the unlikely event of a failure, steering reverts to manual control.

### How It Works

Power for the steering is supplied in the form of hydraulic pressure by a rotary pump connected directly to the rear of a special generator. The pump transmits fluid to and from the power unit through flexible hoses. It operates whenever the engine is running.

The power-steering unit is an integral part of the steering linkage. It is attached to both wheels through adjustable tie rods and to the steering gear by a special steering arm.

Since the steering arm controls the valve mechanism and the steering wheel controls the arm movement, the driver is always in full control of power application.

The booster unit is designed to continue to give "feel of the road" similar to normal driving.

With the wheels in the straight ahead or neutral position, the fluid is fed to the booster unit by a rotary pump but does not react on the steering.

However, as soon as the steering wheel is turned to the right or left, the fluid is directed by a spool valve to the appropriate oil passages to provide steering power.

When the steering wheel is turned to the right, the steering gear arm is turned to the left. This causes the valve spool in the power unit to move to the left, thus opening the valve port and allowing the oil under pressure

from the pump to enter the power unit and move into the right-turn hydraulic passage.

This directs the pressure into the cylinder, where it builds up between the piston and the end of the cylinder.

But since the piston is attached to the car chassis frame and cannot move, the cylinder is forced to the left, moving the tie rods and turning the wheels to the right.

Any oil on the right side of the piston is automatically forced back into the reservoir through the return passage from the right side of the piston.

This line directs pressure to the right side of the piston on left turns, and the right-turn hydraulic passage becomes the return oil line.

The only normal maintenance required is a fluid level check every 1000 miles or 30 days and regular greasing of the steering linkages.

### British Version, Too

Simultaneously with Chrysler's announcement, the first British cars to have power-steering—a batch of 1956 Armstrong - Siddeley Sapphires—reached Australia, but couldn't be unloaded because of the waterfront strike.

Unlike American systems, the Sapphire's Girling unit has a dash control which allows the driver to select full power assistance, half-power, or purely manual steering. ●●●

## HOW CHRYSLER POWER-STEERING OPERATES

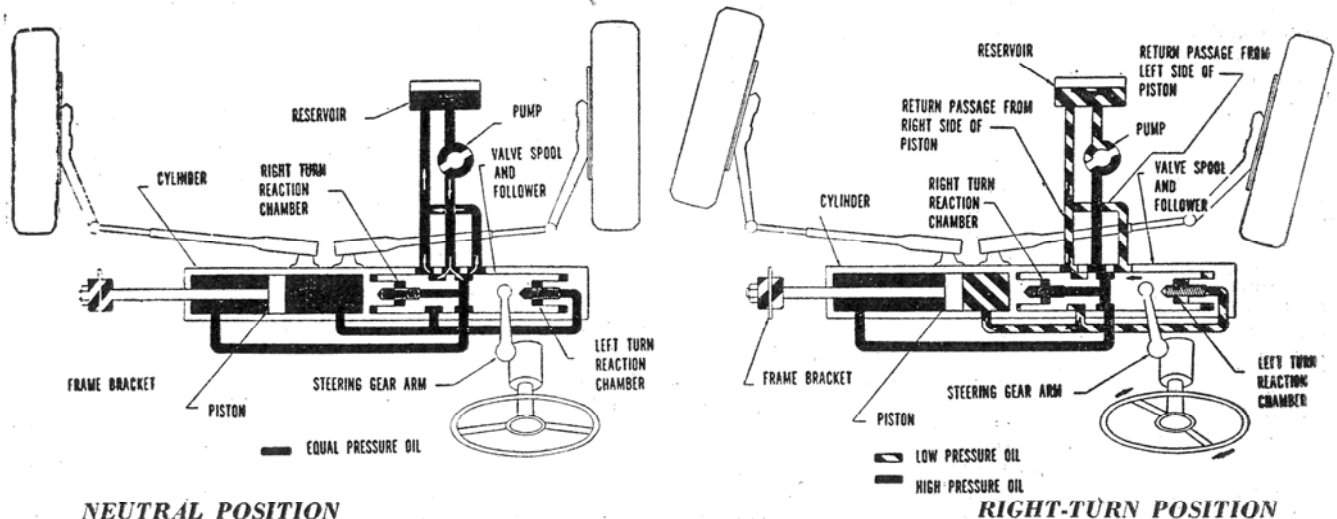

NEUTRAL POSITION

RIGHT-TURN POSITION

## PAST EVENTS

### Ray Miels Memorial President's Breakfast Run

**17 January 2021**

The Ray Miels Memorial president's breakfast run is traditionally a mystery run, to a metropolitan destination. Not too far, so the unknown destination causes no problems.

And so it was this year, with the only abnormality that, completely without precedent, Vince Isola offered to organise the run for the President!

Many would assume that this was Vince putting in a strong bid for future Presidency (Go Vince! Go Vince!) but no, this was not the case.

Vince and Denise had just moved to a new home adjacent to a perfect venue for this run, Henley & Grange Memorial Oval. With its large shady grassed area, a large relatively unused car park, and shelter in case of inclement weather, it was perfect.

A good turnout of members took advantage of this. We had a particularly good spread of "decades" in attendance, with 2 from the 20s, 4 from the 30s, 2 from the 40s, 2 from the 50s, 9 from the 60s and 1 from the 70s.

This venue had a special interest to Lorraine Beythien, because this was where her "marching girls" team practiced. It was obviously a good place for practising, because Lorraine's team won many medals.

In what is perhaps a "first", we even had a canoe in attendance. This wasn't in case the "mystery" part of the run was "extreme". It was because the canoe was being relocated that day, with this being a detour on the way. The Chrysler era Hillman Hunter Safari has a very long roof, making it the ideal vehicle for such a long canoe.

*Richard Tapp*



# PAST EVENTS

## Ray Miels Memorial President's Breakfast Run (ctd)



## PAST EVENTS

### Ray Miels Memorial President's Breakfast Run (ctd)



## PAST EVENTS

### Ray Miels Memorial President's Breakfast Run (ctd)



## PAST EVENTS

### Valentine's Day run to Hahndorf Inn

#### 14 February 2021

With a beautiful morning greeting our members at the CCC clubrooms on February 14<sup>th</sup> (Valentine's Day), our breakfast run to the township of Hahndorf was off to a great start. We had a large number of members who took part in the run up the freeway to Hahndorf and our breakfast at the Hahndorf Inn. Once we reached our destination we found a lot of our members had decided to go direct to the venue as it was closer than going to the clubrooms.

We had a wonderful turnout of 54 people who attended, most being club members. It was pleasing to see some of our members who have been on the sick list attending. We settled into our seats and were treated to a wonderful breakfast - a choice of scrambled eggs, bacon, tomato, mushrooms on a bread pretzel or poached egg, hollandaise sauce, bacon, tomato, mushrooms on a toasted muffin. The venue staff organised orange juice, apple juice and water for the tables as well as plenty of coffee and tea. Some of our members requested some changes to the menu to accommodate them and the staff were more than willing to oblige. I thought the staff and kitchen handled our large group very well.

Once breakfast had been ordered our members spent some time catching up with each other which has been difficult at times since the start of Covid19 back in March 2020. Breakfast arrived and I believe everyone enjoyed their meal and conversations. Following breakfast more conversations followed and I think it was around 11.45am before we made our way out of the venue and into the car park to discuss further exploration of Hahndorf.

Brenton, Sharon, Greg and myself wandered the main street of Hahndorf taking lots of QR code pictures so we could enter the shops and look around. At around 2.30pm we ran into Heather and Chris Bennett who told us about the Wolf Blass Museum where we shared a couple of pizzas and glasses of wine in the beautiful garden surroundings at the back of the museum. After a relaxing lunch we decided it was time to leave and we walked back down to the car park and returned down the freeway to home.

A big thank you to Brenton and Sharon Gibb for organizing this run it was a great day and hopefully we will be able to share more runs in the coming months without any restrictions.

*Ann Lind*



# PAST EVENTS

## Valentine's Day run to Hahndorf Inn (ctd)



# PAST EVENTS

## Valentine's Day run to Hahndorf Inn (ctd)



## PAST EVENTS

### Valentine's Day run to Hahndorf Inn (ctd)



## FROM THE ARCHIVES

### A Royal Obsession

*Trevor Beythien has gone through back issues of our magazines and selected articles worthy of repeating. Thank you Trevor. This is from May/June 2008, issue 176.*

**Richard Tapp**

At the April 2008 meeting I was reading the Buy & Sell board when I noticed an AP3 Chrysler Royal for sale. One owner, 90,000 miles V8, good condition for age. I thought to myself, "I love Chrysler Royals and I haven't got an AP3 - no, pass the board on. (Good Boy)".

Well my mind wasn't really on the rest of the meeting, as you can guess it was elsewhere.

After the meeting I went in search of the Buy & Sell board, read it again and took down the phone no. (Bad Boy). I thought it won't hurt to phone and talk about Royals and glean any further information. So I made the call and the car sounded too good to be true.

So I said to my mate Bob, "How would you like to go for a little drive on Monday." He said "Okay where to?" I said "Castlemaine" and he said "WHAT, what for." I said, "Just to have a look (Good Boy) at an AP3 Chrysler Royal" and I emphasized we would only be looking. Dangerous thing to do.

I picked Bob up at 6 am on Monday and after a rather uneventful journey we arrived at Castlemaine around 2.30 pm and found the address, by use of my Navman. If you haven't got one of these, I highly recommend them. They are brilliant.

We knocked on the door, introduced ourselves to Ron and Edith and said we are here from Adelaide to see the Royal. "Gee, your keen" said Ron and he took us out to the back shed to see the Royal.

Well when he took the covers off and I saw all the chrome and fins I was hooked. (Bad Boy) After giving the car a thorough going over a deal was done.

Now my problems started. How to get it home. Go home, get the trailer and come back for it - too time consuming and expensive due to the price of petrol. Car carrier - too

expensive also, as it would have to go from Castlemaine to Melbourne, Melbourne to Adelaide. So on with the thinking cap and exercise the grey matter. Then came the brainwave. I said to Bob "We'll drive it home. Mechanically it's good - only one minor detail - no brakes.

You could get a brake pedal after two or three pumps. So let's bleed the brakes and see what happens. After a while we finished up with about half a pedal, but it was a solid half pedal. Problem solved.

Now, on to problem two. A small matter of money, neither of us brought much with us, as we were only coming for a look (Good Boy). Now we were buying (Bad Boys). After many mental calculations we figured we could just manage to buy, using our credit and savings card, just until we got home, as I had money at home, but that was no good where we were.

We were about to leave and find some accommodation for the night when Ron and Edith invited us to stay for tea. They were very apologetic, saying it's only a roast. Well it was roast lamb and one of the best roasts I've ever had. After tea they gave us directions to a good motel, where we stayed the night.

Next morning we picked up the car. Ron showed us another shed with a

1956 Mainline Ford, with only 30,000 miles on it. It was his father's and Ron is going to pass it on to his son.

10.30 am departure, all paper work completed, car loaded with spares and we were on our way. We started off slowly at 45 mph - the car ran well. After a while I increased the speed to 50 mph - still ran well. Up to 55 mph - still going well. Then the magical Vic Roads limit of 60 mph which we maintained for the rest of the journey.

Just out of Horsham the engine cut out, backfired, restarted and ran fine until Tailem Bend where we stopped for fuel. After leaving Tailem Bend the engine started cutting in and out, sometimes it didn't refire till I got down to 20 mph. A frightening experience, with a B Double about 20 feet off your back bumper. On the freeway just before the hills it cleared and came good. Thank God, because the way it was running it wouldn't have climbed the hills.

We arrived home at 7.30 pm after a nine hour journey, 750 km and 14.5 mpg. I don't know what it is about Chrysler Royals, I just love them. I would like to thank my mate Bob and my wife Rhonda. Without their help, this adventure would not have been possible.

**Garry Williams**



## MOPAR MEMORIES

### My Apprenticeship with Chrysler Australia

*The image makes a rusty lock  
And memory turns the key  
O spend a moment reading this  
And share these thoughts with me.*

Seeing the photo of the Chrysler factory on the Finsbury Industrial Estate in the Chrysler Restorer number 251 brought back the memory of the start of my working life.

My family had migrated from England leaving November 1951 and after initially going to Bathurst reception camp we'd been sent to a migrant hostel in Eastern Victoria. At the end of the year the hostel closed and rather than returning to England (which a lot of immigrants did) we came to Adelaide. We arrived at the Finsbury Migrant Hostel Christmas 1952.

My school year in Victoria had been a disaster and with all the authority a 15 year old teenager could muster I refused to begin another school year. My parents agreed that I could leave school but only if I obtained an apprenticeship.

So as 1953 began the search was on. Letters were sent, factories visited, difficult telephone calls were made from public phone boxes. To no avail. Full quotas, try again in November.

Broke and bored I began exploring the neighbourhood as far as walking could take me with the occasional bus ride to Port Adelaide, and yes, I'd tried Symes and Martins for an apprenticeship to no avail. (I later worked for them during a Xmas break.)

During one of my wanders I'd strayed onto the Finsbury Industrial Estate which lay along the eastern boundary of the migrant hostel. The estate, which stretched from Junction road to Torrens Road was a remnant of war time industrial production and it must have been very important. It had its own rail line and its own water tower which still stands on Torrens road.

The area was occupied by major companies in large factory style buildings connected by sealed roads. At this time quite a lot were still active and although there was



provision for security and some parts were sealed off I could wander about.

And so I came to the image of the photograph in the magazine. It was hot and the large doors of the building were open and there weren't many workers, I guess it was holiday time. In front of me were metal parts of airplanes, they looked like modern jet stuff.

They weren't building Gloster Meteors because I studied them at school in England. But still.

"Can I help you" He'd come from the shadows at the side of the door whilst I was feasting my eyes.

"Aeroplanes" I waved my arm, "What type"?

"Canberras and things. We just make the bits."

"I'm looking for an apprenticeship."

"We don't do that here" he said "You'll have to go to head office."

"And where is that please."

"Maple Avenue, off the Bay Road. Right" He could have been talking about a back street of New York for all I knew of Adelaide.

"Hang on" and he walked away further inside the building. After a few minutes he returned. "Come with me." And I followed him. There didn't seem to be much activity and we eventually came to a glass windowed office with a man behind a desk. I stood in the doorway, I wasn't invited in, and he looked me up and down.

"Okay, I'll give it a try. Find him a drink or something." he said waving my guide and me away. We walked back to a table set against the wall with some chairs and a refrigerator from which he gave me a coke. "Wait here" he said "He'll be out in a minute" and he walked away.

After a while the man (I can't remember their names) from the office came and told me he'd telephoned Maple Ave. and had spoken with the apprentice training school and yes they have a vacancy for an apprentice fitter and turner and was I interested because they wanted to see me right away.

Just a few wee problems. I had no idea where Maple Avenue was. I had no means of getting there and I wondered if my mother, at home at the hostel looking after my younger brother and sister, would miss me over the next few hours.

My reluctance to go back to school spurred me on. "How do I get there"? I asked.

"Hm. We have a courier going shortly and he'll be coming back late this afternoon. So he can take you."

Two problems solved. I'll take a chance with mum. I don't remember much about the trip or the route but I do remember the vehicle. It was a Desoto Power wagon and nearly new. We called at several factory places on the way.

The courier dropped me off at the gatehouse which stood near the

## MOPAR MEMORIES

### My Apprenticeship with Chrysler Australia (ctd)

Southwestern corner where Maple Ave. joined the Bay Rd (Anzac Highway). A gated yard stood between the gatehouse and the main plant building followed where Maple Ave curved left. On the northern side a red brick office building stood on the corner, followed by a group of three cottages. I was directed to the third cottage which had been modified to become the apprentice training centre. Walls had been removed to create offices at the front and at the rear a workshop.

At this time most of the major companies were setting up apprentice training schools in order to give apprentices a basic level of skills, including safety and personnel skills, before letting them loose in the main plant.

I knocked on the door and a nice young lady answered (I was beginning to appreciate girls) and I was shown in to the office of the Master of Apprentices. I'm not sure of his name. Malatso or Malazer.

With him was Mr. Mc Knight, the apprentice training officer. The interview must have been successful because I returned to Finsbury with papers to sign, a starting time and the need to buy overalls. A basic toolkit would be provided (I still have the toolbox) the cost of which was deducted from my wage which was £3-12s-6d (\$7.25) per week. My board at the hostel was £3-15s (\$7.50) per week.

"And you haven't figured out how to get there yet," said my father. Never the less money was provided and I think it was a Monday morning I travelled by bus along Junction Road to Port Road and by trolleybus to the New Market Hotel on West Terrace and then by bus to Maple Avenue arriving in time to be standing at my bench (the vice end) as instructed with clean overalls, hair combed and a smile on my face when the warning whistle, at twenty eight minutes past seven, sounded. And there will be no whistling or singing. So began my working life with Chrysler Australia.

It lasted twelve months.

In the middle of 1953 my family moved to Salisbury North. This was the age of "move them in and then build the infrastructure" My transport problems compounded and involved tramping down unmade streets, through mud at 6am to catch a train to Adelaide. I was becoming exhausted. We were also scheduled to begin shift work and overtime the following year. The upshot was lots of consultation and my apprenticeship was transferred to L.R.W.E. (as it was then known) at Salisbury.

The twelve months I worked at Chryslers, for a sixteen year old, was full of fascination, excitement and sometimes quite scary. It could never have happened without the support of my family and the chance that brought me to that Finsbury factory door, as pictured.

*Terry Jones*

### Club Name Badges

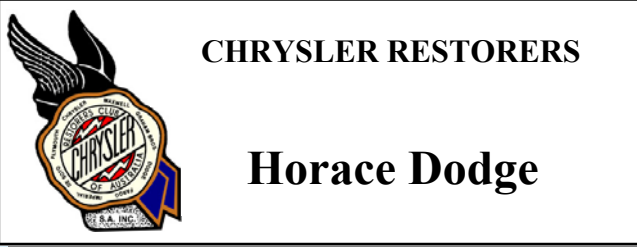

purchase a smaller name badge which is manufactured with your name and club emblem. You may see others wearing them at meetings.

**Available as either:**

- Clear Glaze Acrylic with dual pin and clip \$12.50
- Clear Glaze Acrylic with magnet \$13.50

*Please contact John Goddard at the meetings or by phone at 8443 6311 / 0435 107 854*

Name Badges are supplied by the Club when you join. But if you would like to upgrade, you may

#### CHRYSLER RESTORERS - ORDER FORM FOR NAME BADGES

CLIP TYPE [Dual pin and clip *or* Magnet - circle one]

PHONE (a/h) .....	(day time if different) .....
FULL NAME (print clearly).....	Price.....
2 <sup>nd</sup> badge name.....	Price.....
3 <sup>rd</sup> badge name.....	Price.....
4 <sup>th</sup> badge name.....	Price.....
5 <sup>th</sup> badge name.....	Price.....
<b>Total \$.....</b>	

# MARKET PLACE

## Club Clothing

(John Goddard 0435 107 854)









### CHRYSLER RESTORERS CLUB OF AUSTRALIA SA INC

#### ORDER FORM

861 South Rd,  
Clarence Gardens SA 5039  
[\(08\) 8293 3837](tel:0882933837)

NAME.....

PH:.....

PRODUCT CODE	PRODUCT DESCRIPTION	Mens or Ladies	SIZE	QTY	COST Inc Logo	Em-broider name \$5.00	TOTAL
BIZ P225MS P225LS 	Triton polo top—navy/red/white Mens S M L XL 2XL 3XL 5XL 1/2 Chest 52 55 58 62 65 71 79 Ladies 8 10 12 14 16 18 20 22 24 1/2 Chest 46.5 49 51.5 54 56.5 59 62 65 68				\$34		
JB 4FC 4LSL 	Men's Fine Chambray Shirt Long Sleeve—blue Mens S M L XL 2XL 3XL 4XL 5XL Collar 38 40 41.5 43 45 47 49 51 Chest 57.5 60 62.5 65 68 71 74.5 78.5 Ladies 6 8 10 12 14 16 18 20 22 24 Bust 47 49.5 52 54.5 57 59.5 62 64.5 67 69.5				\$50		
JB 4FCS 4LSLT 	Fine Chambray Shirt Short Sleeve (M) 3/4 sleeve (F) Mens S M L XL 2XL 3XL 4XL 5XL COLLAR 38 40 41.5 43 45 47 49 51 CHEST 57.5 60 62.5 65 68 71 74.5 78.5 Ladies 6 8 10 12 14 16 18 20 22 24 Bust 47 49.5 52 54.5 57 59.5 62 64.5 67 69.5	Blue			\$48		
BIZ J404M J404L 	Geneva Vest Mens S M L XL 2XL 3XL 5XL 1/2 Chest 57 59 61 63 65 70 78 Ladies S M L XL 2XL 1/2 chest 49 52.5 56 59.5 63	Navy/Grap hite			\$72		
BIZ J307M J307L 	Geneva Jacket Mens S M L XL 2XL 3XL 5XL 1/2 Chest 57 59 61 63 65 70 78 Ladies S M L XL 2XL 1/2 chest 49 52.5 56 59.5 63	Navy/Grap hite			\$83		
HS - 4014 	Baseball Cap – inserts on Crown & Peak	Navy/Red	n/a		\$19		

Payment by CARD Please Circle: VISA MASTERCARD

AMOUNT \$ \_\_\_\_\_

Card No:- \_\_\_\_ / \_\_\_\_ / \_\_\_\_ / \_\_\_\_ EXP \_\_ / \_\_ SEC CODE:- \_\_\_\_

CARDHOLDERS NAME: \_\_\_\_\_

SIGNATURE: \_\_\_\_\_

## MARKET PLACE

### NOTICE TO ADVERTISERS

All vehicles offered for sale should quote their registration number or engine number if not registered.

### FOR SALE

Expressions of interest sought for David Crichton's 1916 Dodge Brothers tourer. This is an opportunity to purchase before the vehicle is advertised nationally. Older Full body off restoration. Full Mechanical restoration done by David and late grandfather (and Dick Hart). Bodywork and Paint done professionally. Interior trim, hood and side curtains (vinyl) by Carmine Carofano. Period correct Cathedral Windows. Tour proven vehicle ready to drive and mechanically sound. Excellent condition all round. Garaged and well maintained. \$POA to genuine interested parties only. Flexible with sale date to the right buyer. Located in Adelaide SA. Inspection and test drives welcomed. All Enquiries to Russell Crichton only on 0437 718 175.

1960 Dodge Phoenix. [Rare – only 372 made in Australia]. A worthy restoration project. 8 cyl 318 CID engine. Body in good condition with very few rust holes. Originally painted cream and mainly showing surface rust. Was purchased in a dismantled state with trim, lights etc removed and stored. Previous owner had intended to restore. Engine dismantled and gearbox removed including engine bay items and stored. Three rear windows but no front windscreen. Seating requires reupholstering. Many engine bay related spare parts. No guarantee of completeness. Many other photos available. Body [on wheels] stored in a shearing shed in the country. Remaining parts available for pickup in Adelaide. \$3,250 ono with body delivered

to the Adelaide metro area. Ring Barry 0410 811 240

Parts from a CM Valiant wagon. 4.0 litre Hemi Six Engine. Front end with Hubs Disc brakes and K Frame. Rear suspension with Differential. Dashboard. Assorted other parts. Preferably sold as one package. Andrew Young 0422 005 281

### For Rent

Club member offering long term car storage in an undercover, enclosed shed at Paracombe at a cost of \$50 a fortnight. Owners must have their own insurance. Contact Greg on 0408 809 603 if you are interested. Happy motoring!

### WANTED

Camshaft for Plymouth 30U; later type that has oil pump drive. Believed that 31 and 32 Plymouth use the same camshaft. John Tatti 0409 437 327

1929 Dodge DA gearbox. Malcolm on 08 8278 6813

*[Bold adverts are new this issue]*



**YOU BRING THE CARS,  
WE'LL BRING THE  
HowTo.**

A Stratco shed means any 'Car Enthusiast' can be with their Chrysler all year round. And for the HowTo, ring fellow enthusiast Adam Witkowski on 0439 685 059 for 'club rates'!!!

## Wormald Canvas

*For Canvas Goods & Repairs*

- All Canvas Products & Repairs
- Caravan Annexes
- Boat Covers and Canopies
- Shade Cloth Fabrication
- Ute Tonneau Covers
- Camper Trailers
- Trailer Covers
- Tents & Swags
- Tarpaulins

4-6 Archimedes Place  
Golden Grove SA 5125  
**Ph (08) 8288 7788**  
Fax (08) 8288 7188  
contact@wormaldcanvas.com.au  
[www.wormaldcanvas.com.au](http://www.wormaldcanvas.com.au)

**RSA**  
RUBBER SEALS AUSTRALIA  
EST 1996

USE CODE  
"TORQUES"  
AT THE CHECKOUT ON OUR WEBSITE TO  
RECEIVE 5% OFF YOUR ORDER \*

**Rubber Seals Australia**

**Contact**  
Email: [rubberseals@yahoo.com.au](mailto:rubberseals@yahoo.com.au)  
Website: [www.rubbersealsaustralia.com](http://www.rubbersealsaustralia.com)  
Phone: (08) 8326 7066  
Find us on Facebook

\* We specialise in Australian Chryslers and have a large product range for many other popular makes & models.  
\* South Australian based manufacturer and supplier of quality windscreen seals, door seals, boot seals, door belts, bailey channels and lockstrips.  
\* THIS OFFER IS NOT VALID WITH ANY OTHER DISCOUNTS \*

## WILLSHIRE™

*"It's what's on the inside that counts"*



### CHRYSLER SPECIALISTS

- Full Re-Trims • Head Linings
- Steering Wheel Re-covering • Carpets & Door Trims



### INTERIORS & SOFT-TOPS

- Full Restorations • Seat & Foam Repairs • Carpets
- Vinyl Welding • Leather Trim • Custom Soft-Tops



### SEAT BELTS & RESTRAINTS

- Seat Belt Supply, Service & Repairs
- Classic Car / Compliance Fitments
- Restraint & Anchor Point Installation

4 Deacon Ave, Richmond SA 5033 • P: 8292 2500 • E: [sales@willshire.com.au](mailto:sales@willshire.com.au)

[www.willshire.com.au](http://www.willshire.com.au)

# Beauty is in the eye of the beholder

We understand the passion and the sheer emotional attachment motoring enthusiasts have for their special vehicles - even Goggomobils. When it comes to insurance for your special car, daily drive, bike or your home, there's one person you should talk to a fellow enthusiast at Shannons. You can even pay your premium monthly at no additional cost.

So call Shannons for a quote on 13 46 46 [www.shannons.com.au](http://www.shannons.com.au)

**Insurance for motoring enthusiasts | call134646 for a quote | [Shannons.com.au](http://Shannons.com.au)**

Shannons limited is an authorised representative of Australian Alliance Insurance Company Limited the issuer of this product. Refer to the product disclosure statement by calling134646

If undeliverable, please return to:  
C.R.C.A., SA Inc.  
P.O. Box 667  
PLYMPTON SA 5038  
'THE CHRYSLER COLLECTOR'

**PRINT  
POST**  
PP 100001454

**POSTAGE  
PAID  
AUSTRALIA**

**Priority**